

COMMON SAFETY STANDARDS

INTRODUCTION

The Delaware Department of Transportation has adopted the following common safety standards for use by permittees when in transit within Delaware. The safety standards have been adapted from the "Guide for Maximum Dimensions and Weights of Motor Vehicles and for the Operation of Non-divisible Load Oversize and Overweight Vehicles" prepared by the Subcommittee on Highway Transport and officially adopted by the American Association of State Highway and Transportation Officials (Revised November 1991). They have been further refined by the Northeast Association of State Transportation Officials (NASTO) Highway Transport Committee for use as a common set of standards for all movements throughout the region.

DAYS AND HOURS OF OPERATION

Permitted vehicles may move Monday through Friday, from sunrise to sunset, unless otherwise authorized or prohibited by this section or the permit.

In designated congested areas, the Department may prohibit permitted vehicles from moving during AM and/or PM commuter travel periods; and/or authorize permitted vehicles to move during designated times between sunset and sunrise, subject to special lighting requirements identified herein.

Due to the amount of highway traffic on holidays, vehicles and loads requiring oversize and/or overweight permits shall be prohibited from traveling on those days. Prohibited holidays include New Year's Day, Memorial Day, Independence Day, Labor Day, Thanksgiving Day, the day after Thanksgiving, and Christmas. Movement of such vehicles and loads may also be prohibited on any other days or hours when such movements may substantially affect the safety of the motoring public. Ship Permits are exempt from this prohibition.

Superloads and any other oversize and/or overweight moves that can not move at normal posted highway speeds (within 10 mph) are restricted from moves in Kent and/or Sussex County on Monday morning prior to 12 Noon and Friday afternoon after 12 Noon during the timeframe from May 15th to October 15th. This restriction applies to the following roads, US 9, US 13, US 113, SR 1, SR 18, SR 24, SR 26, SR 54, and SR 404.

INCLEMENT WEATHER

No movement shall be permitted when road conditions, weather conditions, or visibility make traveling hazardous to the operator or the driving public. If a permitted vehicle is underway when such conditions occur, the driver shall be required to proceed to a safe place off the roadway and park until conditions warrant safe travel.

SPEED LIMITS

Vehicles and loads requiring permits may travel at the posted maximum speed limits unless specifically prohibited by the permit.

ROUTING

The permit shall authorize movement only on the pavement portion of those highways specified in the permit. The permit does not authorize movement upon shoulders.

Vehicles and loads requiring permits should be routed around highway construction and maintenance projects and shall be routed around certain bridges or roadways in a way that creates the least hazard and inconvenience to both the mover and the public.

The permit is only for the route designated. The permit is only issued for movement on state maintained roadways (entire road network with the exception of some local city/town streets). Individual city or town's rules/regulations may govern movement off the permitted route.

Every effort should be made to use the most suitable road network, which is closest to a straight line projected between the point of origin and final designation of the load.

ESCORTS

Escort vehicle(s) shall be a single unit non-permitted vehicle, no smaller than a compact car. The escort vehicle shall not be attached to any other vehicle.

Escort vehicle(s) shall escort only one oversize vehicle or load. More restrictive conditions may be required on high volume highways or when the lane width is less than twelve (12) feet.

One (1) escort vehicle is required for vehicles and loads more than twelve (12) feet in width but not exceeding fourteen (14) feet. The escort vehicle shall be behind an over width vehicle or load on a multi-lane highway, and in front of an over width vehicle or load on a two-lane highway.

Two (2) escort vehicles are required for vehicles and loads more than fourteen (14) feet in width. One (1) escort vehicle shall be in front of the over width vehicle or load and one (1) behind. A separate state police escort (third escort) is required for vehicles and loads more than fifteen (15) feet in width.

Vehicles and loads eighty-five (85) feet or more in overall length are required to have one (1) rear escort vehicle. Vehicles and loads one hundred (100) feet or more in overall length are required to have two (2) escorts, one (1) in front, and one (1) in the rear. Vehicles and loads one hundred twenty (120) or more in length are required to have a separate state police escort (third escort).

Two (2) escort vehicles are required for vehicles and loads fifteen (15) feet or more in height. One (1) escort vehicle shall be in front of the over height vehicle or load and one (1) behind. A separate state police escort (third escort) is required for vehicles and loads seventeen feet six inches (17' 6") or more in height.

Vehicles and loads with fifteen (15) feet or greater rear overhang shall have one (1) rear escort unless the permit specifies otherwise.

Two (2) escort vehicles, one (1) in front and one (1) behind the oversize vehicle are required when previous paragraphs separately require one (1) escort in the front and one (1) behind for multiple conditions.

Two (2) escort vehicles are required for vehicles and loads over 120,000 lbs.weight. One (1) escort vehicle shall be in front of the over weight vehicle or load and one (1) behind. A separate state police escort (third escort) is required.

A single Delaware State Police escort can escort up to a maximum of two loads in a single move if the loads are moved at the same time, other required escorts are available as stated above, and communication is present between the loads.

Vehicles and loads that are only overweight or are twelve (12) feet or less in width and that cannot move freely with the flow of traffic may be subject to escort requirements.

Escort Vehicles shall have visual contact with the permitted vehicle and have two-way radio communication with the driver of the permitted vehicle.

WARNING FLAGS

Required warning flags shall be in evidence during daylight hours. Red or orange fluorescent warning flags shall be at least eighteen (18) inches square. Flags shall be securely fastened to the vehicle or load by at least one corner of the flag or securely mounted on a staff.

Warning flags are required on vehicles and loads, which exceed legal width. These vehicles and loads are required to bear flags at the extremities of the vehicle or load as shown in Figure B-1.

Flags are also required on vehicles and loads which exceed legal length or which have a rear overhang in excess of four (4) feet. There shall be a single flag at the extreme rear if the over length or projecting portion is two (2) feet wide or less. Two (2) flags are required if the over length or projecting portion is wider than two (2) feet and shall be located to indicate maximum width. (See Figure B-2)

WARNING LIGHTS

General Lighting Requirements

Load hauling vehicles and escort vehicles shall travel with low beam headlights on at all times.

While not required in Delaware, load-hauling vehicles may display a flashing 360-degree yellow (amber) light at an elevation above the highest point of the vehicle. A second flashing 360-degree light may be at the rear of the load if the load obstructs the visibility of the 360-degree light on the load-hauling vehicle. The 360-degree light shall be visible in all directions from a distance of 1,000 feet during daylight hours with a flash rate of 60 to 90 flashes per minute (FPM). The 360-degree light lens shall be at least 4 inches high whose minimum width or diameter at that height is 4 3/4 inches.

While not required in Delaware, warning lights for escort vehicles shall be located on the roof of the vehicle perpendicular to the length of the escort vehicle. The warning light bar shall be a minimum of 43 inches and a maximum of 52 inches long, a minimum of 10 inches and a maximum of 13 inches wide, and a minimum of 4 inches with a maximum of 8 inches high, consisting of flashing or strobe lights. Each warning light bar shall consist of a minimum of four lights. If flashing lights are used, they shall consist of at least two 95 and two 150 minimum FPM rotators; mirrors shall be placed diagonally between lights (mirrors to be reflective on both sides). All lights shall be visible on a 360-degree basis from the vehicle for a distance of 1,000 feet and arranged with at least two lights in each end of the bar light. The dome cover color shall be amber. The warning lights may be displayed while escorting the load in Delaware.

Whenever the rear running lights, stop lights, turn signals, or hazard-warning lights are obstructed by the load on a vehicle, lighting equipment shall be displayed on the rear of the load equivalent to the obstructed lights or signals.

Load Warning Lights

Warning lights shall be used for authorized night operations as shown in Figures B-3 and B-4.

For over width loads uniform in width, place amber lights on the forward corners of the load and red lights on the rear corners of the load as shown in Figure B-3.

If the load is over width for its entire length with a wider portion near the middle of the load, place red and amber lights at the rear and front corners of the load, respectively, with amber lights on the sides at the extreme limits of the load as shown in Figure B-3.

If the load is non-uniform in width, place red and amber lights at the rear and front corners, respectively of the over width portion as shown in Figure B-3.

For loads of legal width that are over length with a rear overhang exceeding four (4) feet, place four red lights on the rear and sides of the overhanging portion of the load. Amber lights are required at least every 6 feet on both sides of the overhang as shown in Figure B-4.

WARNING SIGNS

Warning signs shall be in evidence during all oversize movements. Load hauling vehicle warning signs shall be at least seven (7) feet long and eighteen (18) inches high. The sign's background shall be yellow with black lettering, and for night moves, of high-intensity reflective material. Letters shall be at least ten (10) inches high with a 1.41 inch brush stroke. Note: If Series E Modified is used, the brush stroke is to be two (2) inches.

Vehicles and loads exceeding legal width shall display two signs with the wording "OVERSIZE LOAD". One sign shall be on the front of the vehicle. The other shall be on the rear of the load; however, if the sign cannot be attached to, or is not legible on the load, then the sign shall be attached to the rear of the vehicle itself. Refer to Figure B-5.

Vehicle and loads exceeding legal length or rear overhang shall be required to display two signs with the wording "OVERSIZE LOAD". One sign shall be on the rear of the over length or overhanging part of the load; however, if the sign cannot be attached or is not legible here, then the sign shall be attached to the rear of the vehicle itself. The other sign shall be attached to the front of the vehicle. Refer to Figure B-6.

Escort vehicles shall display a sign on the roof or front and rear of the escort vehicle that is at least five (5) feet long and twelve (12) inches high with eight (8) inch high letters. For roof-mounted signs, the sign shall be legible on both sides with the wording "OVERSIZE LOAD". The sign shall be mounted on the roof perpendicular to the length of the escort vehicle. For front and rear mounted signs the legend shall read "OVERSIZE LOAD".

Warning signs shall not obstruct lights and other safety devices on the vehicle with load or on the escort vehicle.

APPENDIX B

Delaware Common Safety Standards for Permit Move

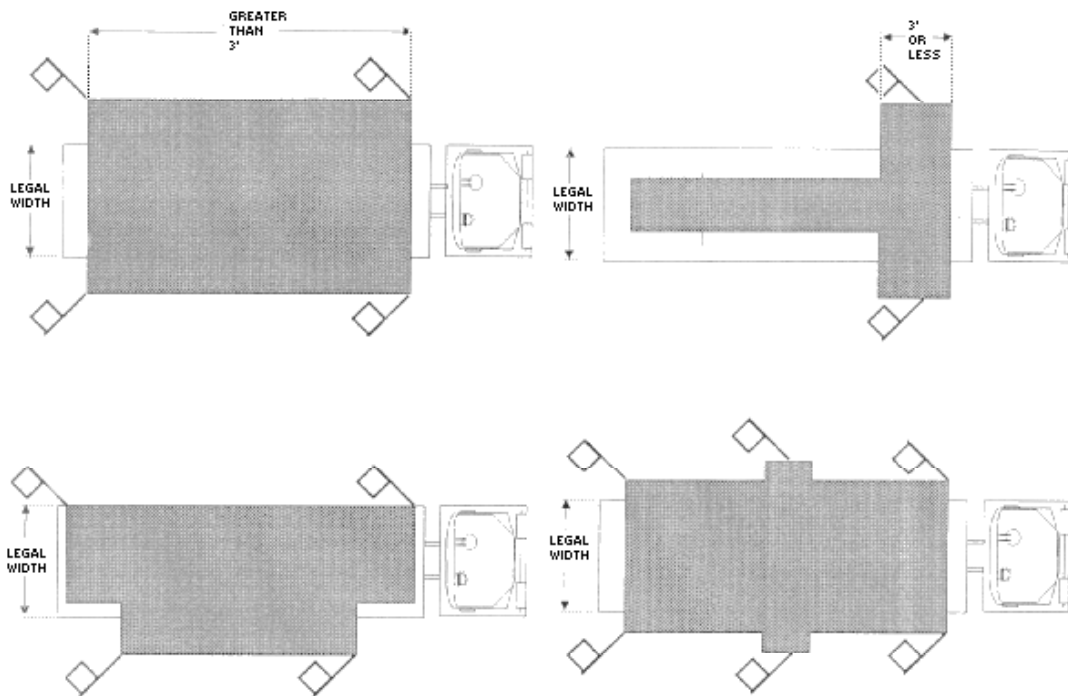

Figure B-1 Required Warning Flags on Overwidth Loads.
Note: Use of flags is not to increase the overall load width.

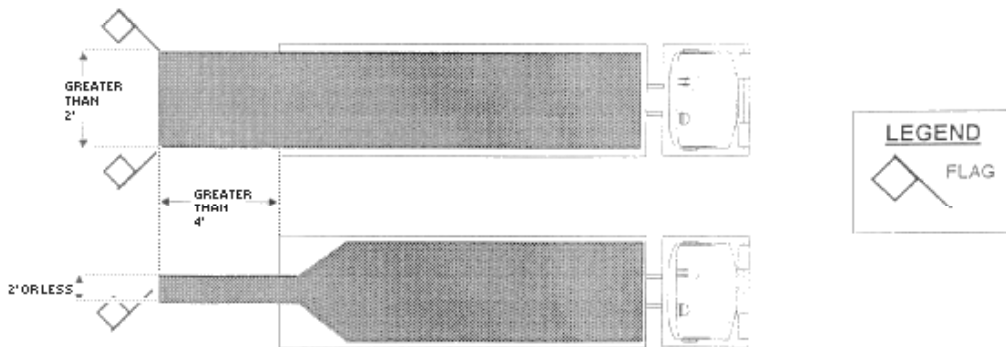

Figure B-1 Required Warning Flags on Overlength Load or Loads with a Rear End Overhang of more than four (4) feet.
Note: Use of flags is not to increase the overall load width.

PAGE 1
#NAG-103.DS4

APPENDIX B
 Delaware Common Safety Standards for Permit Move

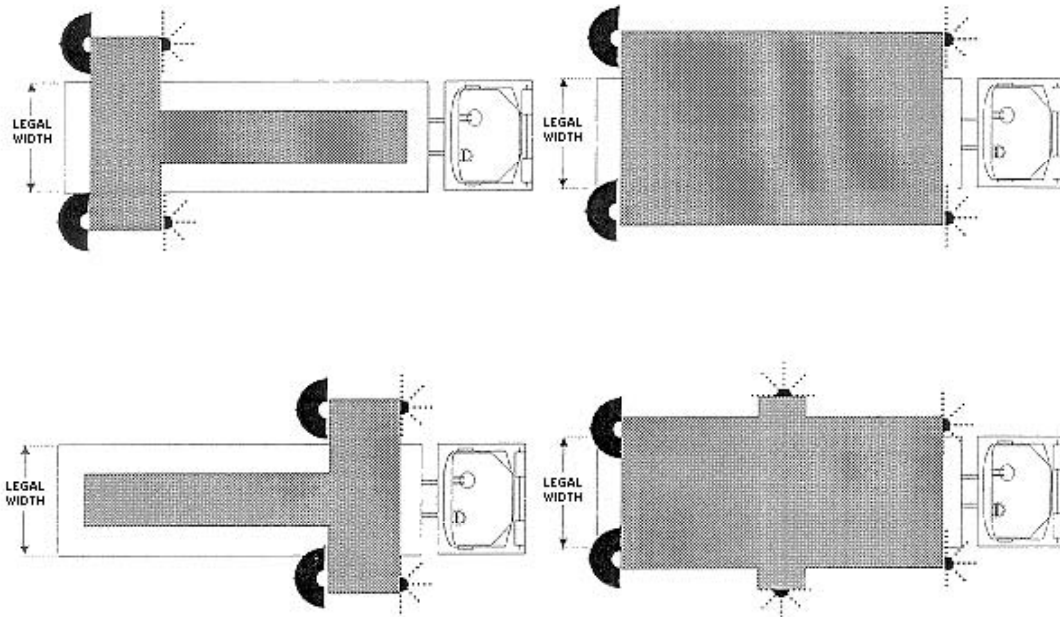

Figure B-3 Required Warning Lights on Overwidth Loads.

NOTE: Amber reflectors or amber lights are required at least every 6 feet along both sides of the overwidth portion of the vehicle or load.

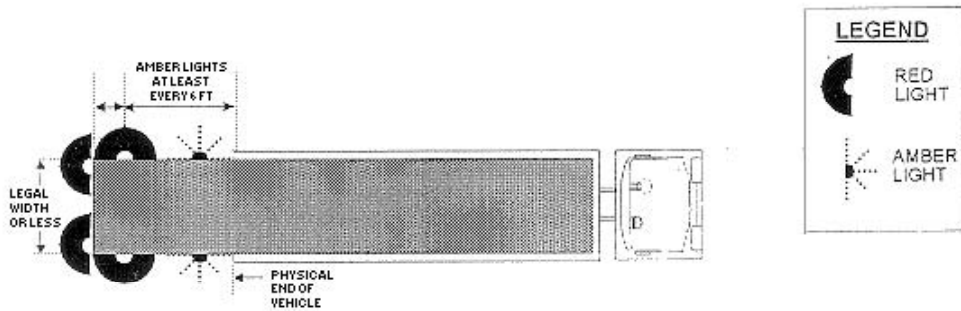

Figure B-4 Required Warning Lights on Overlength Load or Loads with a Rear End Overhang of more than four (4) feet.

APPENDIX B
Common Safety Standards for Permit Move

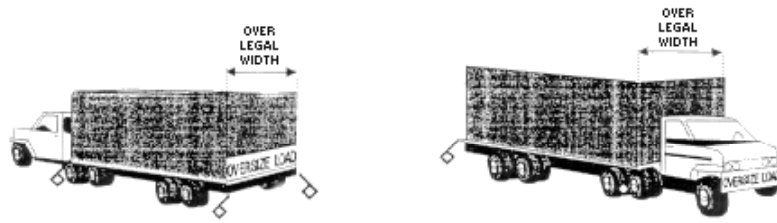

Figure B-5 Warning Signs on Vehicle or Load Over Legal Width

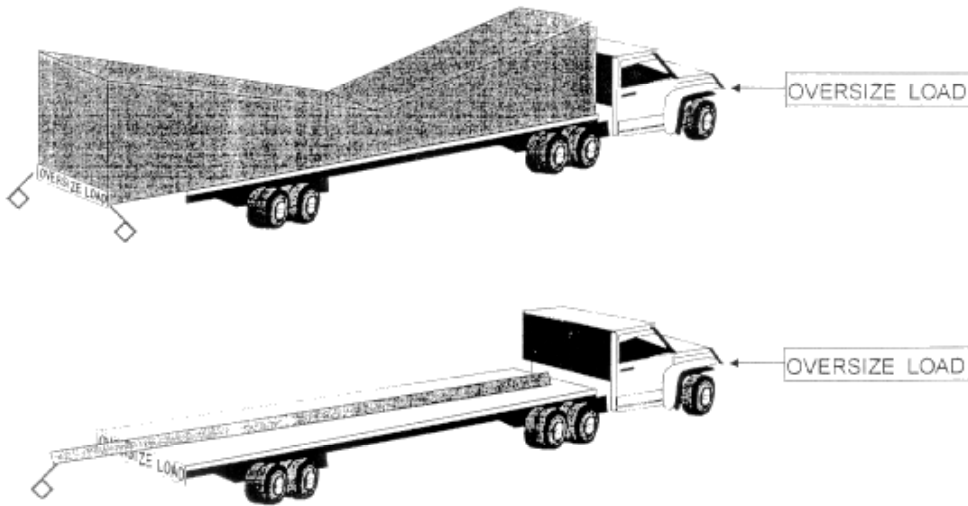

Figure B-5 Warning Signs on Loads Overlength or With Rear End Overhang

© NASHTDA DSA